

|                                 |                  |
|---------------------------------|------------------|
| <b>Johannes Herrmann</b>        |                  |
| Sheet: /                        |                  |
| File: MW_ODMR.sch               |                  |
| <b>Title: MW_ODMR</b>           |                  |
| Size: A4                        | Date: 2016-12-20 |
| KiCad E.D.A. kicad 4.0.2-stable | Rev: 2.0         |
|                                 | Id: 1/16         |

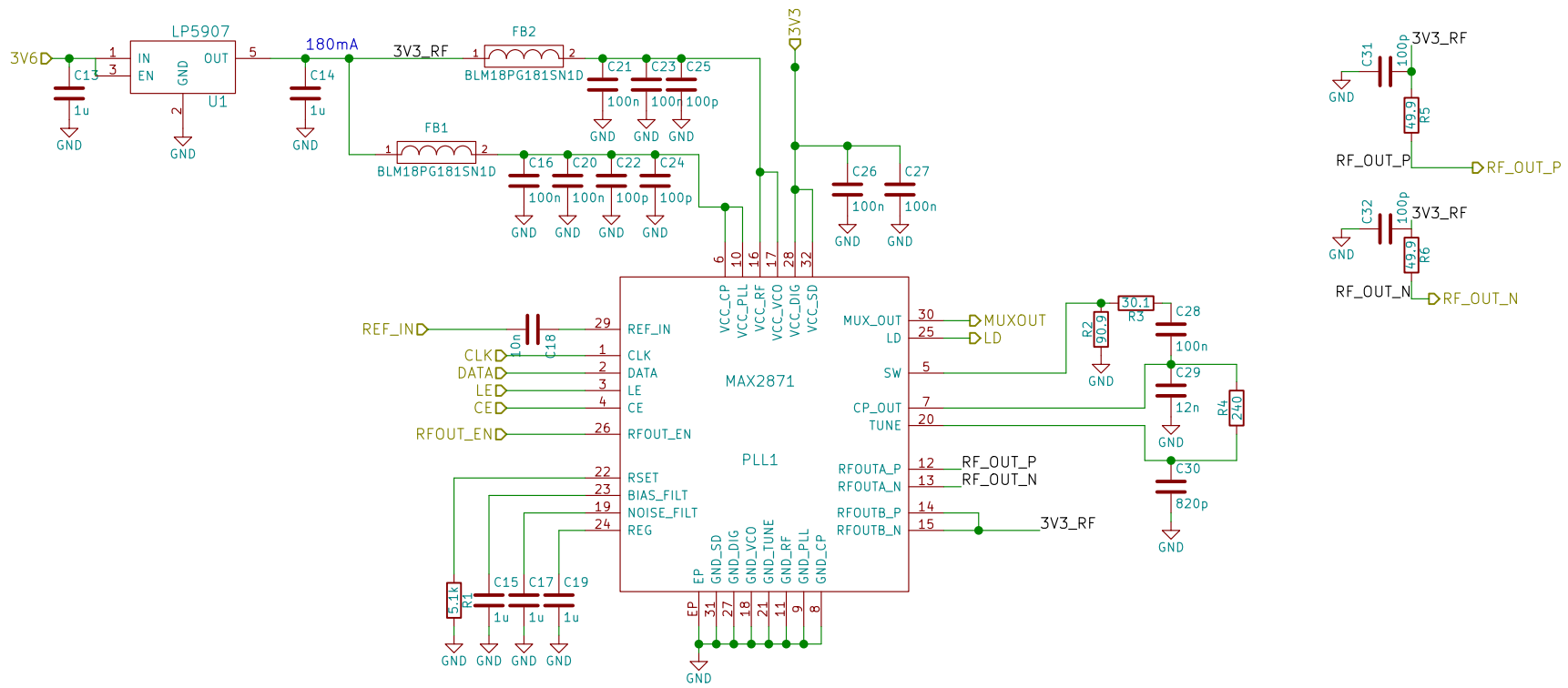



**Johannes Herrmann**

Sheet: /MW\_Source1/  
File: MW\_Source.sch

**Title: MW\_Source**

Size: A4 Date: 2016-12-19

KiCad E.D.A. kicad 4.0.2-stable

**Rev: 1**

Id: 2/16

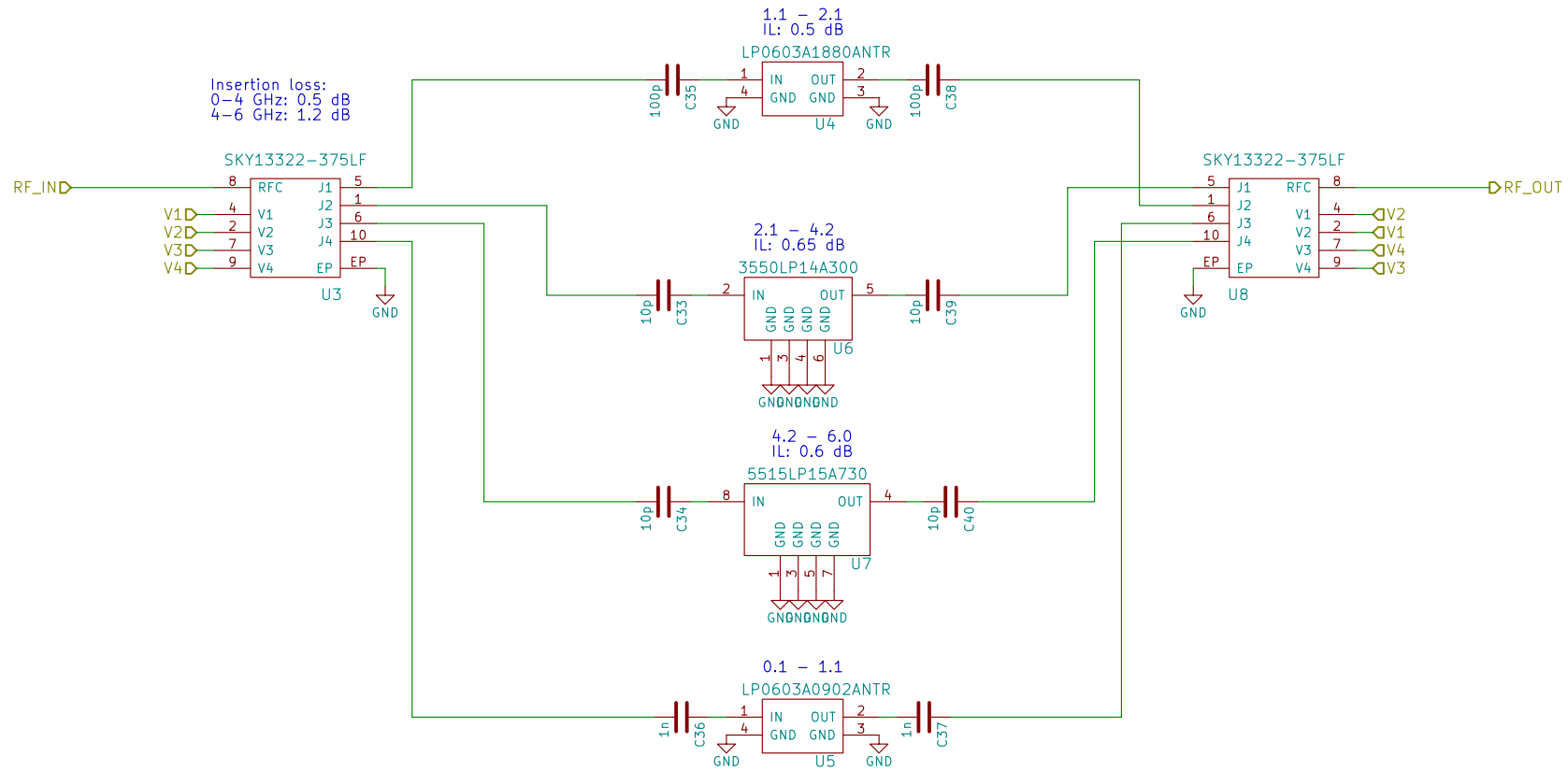

Johannes Herrmann

Sheet: /Filter\_Bank1/

File: Filter\_Bank.sch

**Title: Filter\_Bank**

Size: A4 Date: 2016-12-20

KiCad E.D.A. kicad 4.0.2-stable

Rev: 1

Id: 3/16

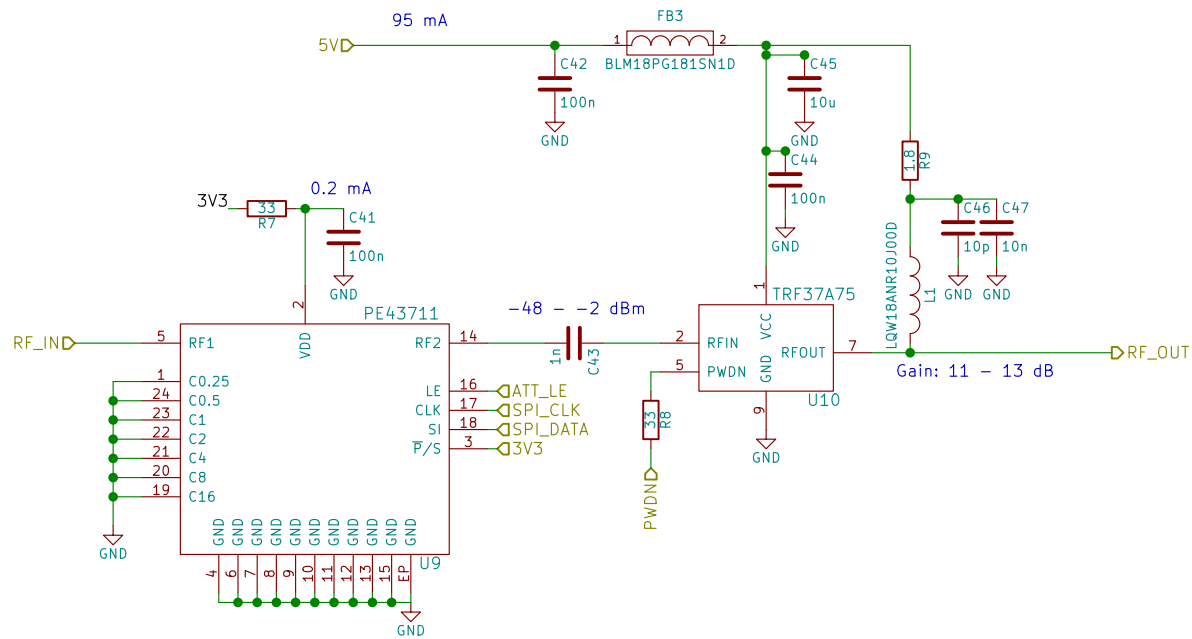

**Johannes Herrmann**

Sheet: /MW\_Amp1/  
File: MW\_Amp.sch

**Title: MW\_Amp**

Size: A4 Date: 2017-01-03

KiCad E.D.A. kicad 4.0.2-stable

**Rev: 1**

Id: 4/16

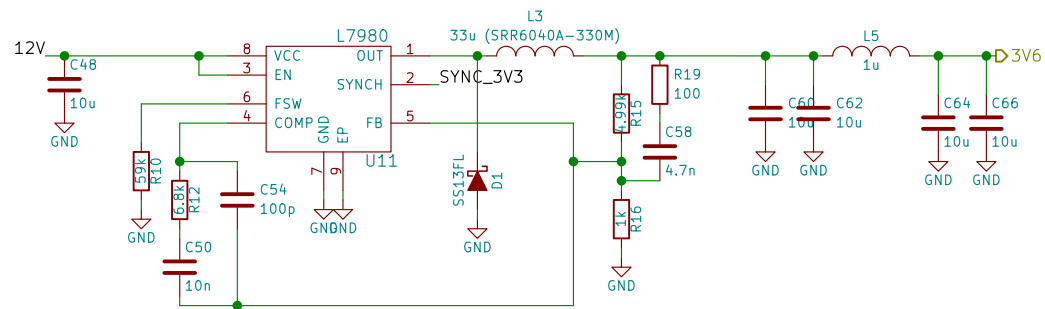
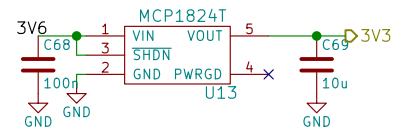
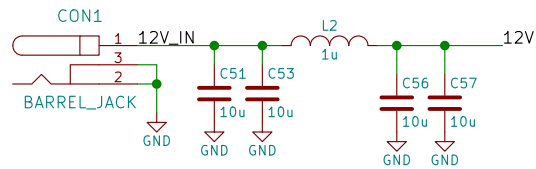

SYNC\_3V3 SYNC\_5V

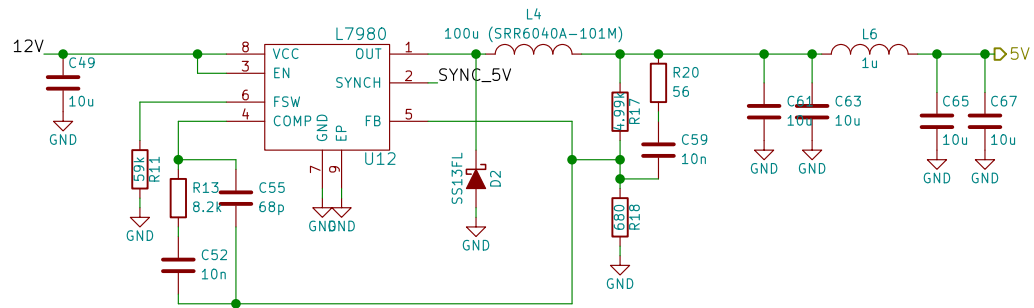

Johannes Herrmann

Sheet: /Power/  
File: Power.sch

Title: Power

Size: A4 Date: 2016-12-20  
KiCad E.D.A. kicad 4.0.2-stable

Rev: 1  
Id: 5/16

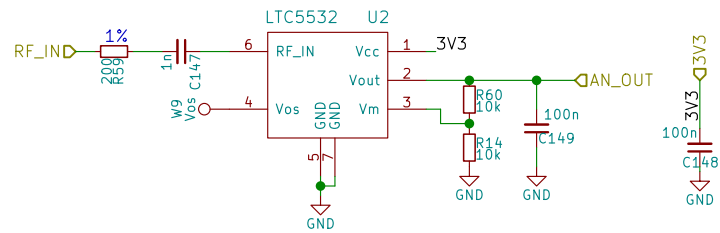

**Johannes Herrmann**

Sheet: /Power\_Sense1/

File: Power\_Sense.sch

**Title: Power\_Sense**

Size: A4

Date: 2017-05-24

KiCad E.D.A. kicad 4.0.2-stable

**Rev:**

Id: 14/16

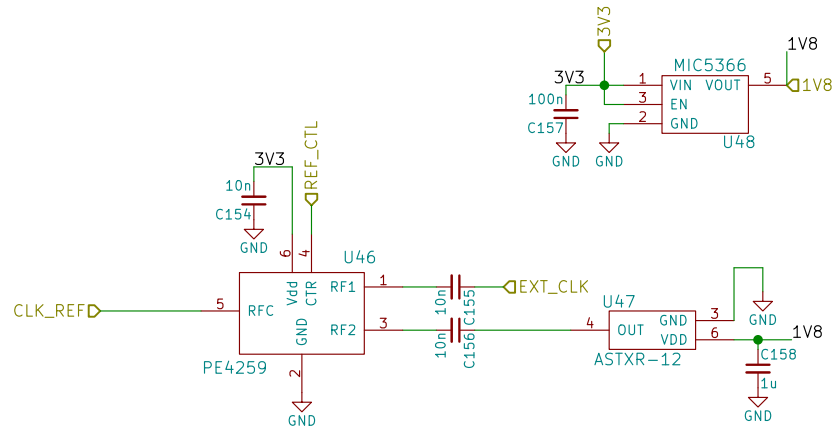

Sheet: /CLK\_REF/  
File: CLK\_REF.sch

**Title:**

Size: A4  
KiCad E.D.A. kicad 4.0.2-stable

Date:  
Rev: 16/16